

SCORBOT-ER IX

User's Manual

2nd Edition

Catalog # 100066 Rev.B



WARNING!

**The SCORBOT ROBOT is DANGEROUS
and can cause severe injury.**

USE WITH EXTREME CAUTION.

**Set up a protective screen or
guardrail
around the robot to
KEEP PEOPLE AWAY
from its working range.**

Copyright ©1996, 1999 by Eshed Robotec

Catalog #100066 Rev.B

ISBN 965-291-068-6

(March 1996) March 1999 Reprinted/PDF version

Every effort has been made to make this book as complete and accurate as possible. However, no warranty of suitability, purpose, or fitness is made or implied. Eshed Robotec is not liable or responsible to any person or entity for loss or damage in connection with or stemming from the use of the software, hardware and/or the information contained in this publication.

Eshed Robotec bears no responsibility for errors which may appear in this publication and retains the right to make changes to the software, hardware and manual without prior notice.

ESHED ROBOTEC INC.

444 East Industrial Park Drive

Manchester, NH 03109 USA

Tel: 1-800-777-6268

Tel: (603) 625-8600

Fax: (603) 625-2137

Table of Contents

CHAPTER 1	Unpacking and Handling	
	Unpacking the Robot	1-1
	Handling Instructions	1-2
	Acceptance Inspection	1-2
	Repacking for Shipment	1-3
CHAPTER 2	Specifications	
	Structure	2-2
	Work Envelope	2-3
CHAPTER 3	Safety	
	Precautions	3-1
	Warnings	3-2
CHAPTER 4	Installation	
	Preparations	4-1
	Controller and Computer/Terminal Setup	4-1
	Robot Setup	4-1
	SCORBOT-ER IX Installation	4-3
	Controller Installation	4-3
	Robot Installation	4-3
	Homing the Robot	4-4
	Gripper Installation	4-5
	Pneumatic Gripper	4-5
	DC Servo Gripper	4-7
	Activating the Gripper	4-8
CHAPTER 5	Operating Methods	
	Software	5-1
	ACL	5-1
	ATS	5-1
	ACLOff-line	5-2
	SCORBASE Software	5-2
	Teach Pendant	5-2
CHAPTER 6	Drive System	
	Motors	6-2
	DC Motor Structure	6-3
	SCORBOT-ER IX Motors	6-4
	Harmonic Drive Gears	6-5
	Harmonic Drive Gear Ratios	6-6
	Axis Gear Ratios	6-7

CHAPTER 7	Position and Limit Devices	
	Encoders	7-1
	Encoder Resolution	7-3
	End of Travel (Limit) Switches	7-4
	Hard Stops	7-5
	Home Switches	7-6
CHAPTER 8	Wiring	
	Robot (Power) Cable and Connector	8-2
	Encoder Cable and Connector	8-3
CHAPTER 9	Maintenance	
	Daily Operation	9-1
	Periodic Inspection	9-2
	Troubleshooting	9-2
	Messages	9-6

Unpacking and Handling

This chapter contains important instructions for unpacking and inspecting the SCORBOT-ER IX robot arm.

☞ *Read this chapter carefully before you unpack the SCORBOT-ER IX robot and controller.*

Unpacking the Robot

The robot is packed in expanded foam, as shown in Figure 1-1.

To protect the robot during shipment, a metal plate holds the gripper- mounting flange to the robot base. The plate is fixed to the flange with three bolts and to the base with two bolts. Use a 3mm hex socket wrench to detach these bolts.

Save these bolts and the plate. You will need them should you repack the robot for shipment.

Save the original packing materials and shipping carton. You may need them later for shipment or for storage of the robot.

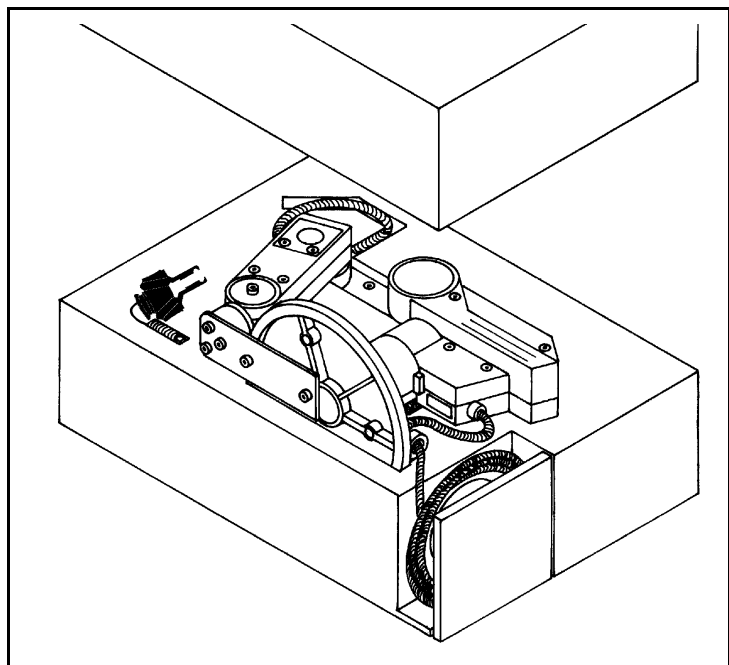

Figure 1-1: SCORBOT-ER IX in Packing

Handling Instructions

The robot arm weighs 38 kilos (83 pounds). Two people are needed to lift or move it.

Lift and carry the robot arm by grasping its body and/or base. Do not lift or carry the robot arm by its upper arm or forearm.

Acceptance Inspection

After removing the robot arm from the shipping carton, examine it for signs of shipping damage. If any damage is evident, do not install or operate the robot. Notify your freight carrier and begin appropriate claims procedures.

The following items are standard components in the **SCORBOT-ER IX** package. Make sure you have received all the items listed on the shipment's packing list. If anything is missing, contact your supplier.

Item	Description
SCORBOT-ER IX Robot Arm	Includes: Cabling with air hoses; Hardware for mounting robot: 3 M8x60 bolts; 3 M8 washers; 3 M8 nuts.
Gripper: 2 options	Pneumatic Gripper includes: pneumatic solenoid valve; Hardware for mounting gripper: 6 4Mx8 screws.
	Electric DC Servo Gripper with encoder includes: Hardware for mounting gripper: 4 M4x10 screws.
ACL Controller-B	Includes: Power Cable 100/110/220/240VAC; RS232 Cable; 3 driver cards for 6 axes.
	Optional: Emergency By-Pass Plug (required when TP not connected) Additional driver cards for control of up to 12 axes; Auxiliary multiport RS232 board, cable and connectors.
Teach Pendant: optional	Includes: mounting fixture; connector adapter plug; <i>Teach Pendant for Controller-B User's Manual</i>
Software	ATS (Advanced Terminal Software) diskette; includes ACLoff-line software
	SCORBASE Level 5 Software diskette
Documentation	<i>SCORBOT-ER IX User's Manual</i>
	<i>ACL Controller-B User's Manual</i>
	<i>ACL for Controller-B Reference Guide</i>
	<i>ATS for Controller-B Reference Guide</i>
	<i>ACLoff-line User's Manual</i>
	<i>SCORBASE Level 5 for Controller-B Reference Guide</i>

Repacking for Shipment

Be sure all parts are back in place before packing the robot.

When repacking the robot for shipping, **bolt the flange and base to the metal plate**. Failure to do so may result in irreversible damage to the arm, particularly to the Harmonic Drive transmissions. Also be sure to secure the cables around the foam spool.

The robot should be repacked in its original packaging for transport.

If the original carton is not available, wrap the robot in plastic or heavy paper. Put the wrapped robot in a strong cardboard box at least 15 cm (about 6 inches) longer in all three dimensions than the robot. Fill the box equally around the unit with resilient packing material (shredded paper, bubble pack, expanded foam chunks).

Seal the carton with sealing or strapping tape. Do not use cellophane or masking tape.

This page intentionally left blank.

Specifications

The following table gives the specifications of the **SCORBOT-ER IX** robot arm.

Robot Arm Specifications	
Mechanical Structure	Vertical articulated, enclosed casting
Number of Axes	5 plus gripper
Axis Movement	Axis Range Effective Speed
Axis 1: Base rotation	270° 79°/sec 112°/sec
Axis 2: Shoulder rotation	145° 68°/sec 99°/sec
Axis 3: Elbow rotation	210° 76°/sec 112°/sec
Axis 4: Wrist pitch	196° 87°/sec 133°/sec
Axis 5: Wrist roll	737° 166°/sec
Maximum Operating Radius	691mm (27.2") without gripper
End Effector: options:	Pneumatic Gripper
	Electric DC Servo Gripper
Hard Home	Fixed position on all axes
Feedback	Incremental optical encoders with index pulse
Actuators	DC servo motors
Transmission	Harmonic Drive gears and timing belts
Maximum Payload	2 kg (4.4 lb.), including gripper
Position Repeatability	±0.09mm (0.0035")
Weight	38 kg (83 lb.)
Ambient Operating Temperature	2°–40°C (36°–104°F)

Structure

The SCORBOT-ER IX is a vertical articulated robot, with five revolute joints. With gripper attached, the robot has six degrees of freedom. This design permits the end effector to be positioned and oriented arbitrarily within a large work space.

Figures 2-1 and 2-2 identify the joints and links of the mechanical arm.

Each joint is driven by a permanent magnet DC motor via a Harmonic Drive gear transmission and timing belt.

The movements of the joints are described in the following table:

Axis No.	Joint Name	Motion	Motor No.
1	Base	Rotates the body.	1
2	Shoulder	Raises and lowers the upper arm.	2
3	Elbow	Raises and lowers the forearm.	3
4	Wrist Pitch	Raises and lowers the end effector.	4
5	Wrist Roll	Rotates the end effector.	5

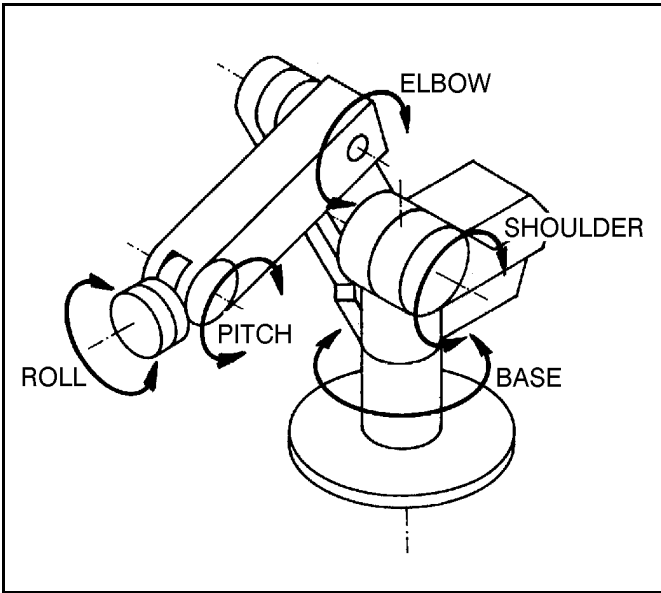

Figure 2-1: SCORBOT-ER IX Joints

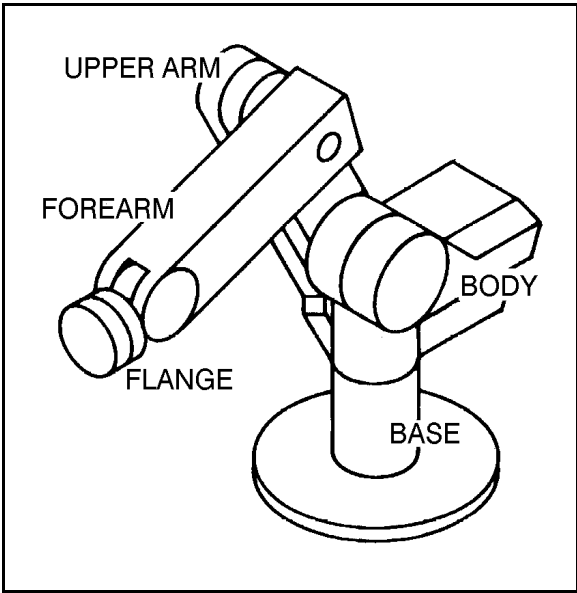

Figure 2-2: SCORBOT-ER IX Links

Work Envelope

The length of the links and the degree of rotation of the joints determine the robot's work envelope. Figure 2-3 shows the dimensions and reach of the SCORBOT-ER IX, while Figure 2-4 gives a top view of the robot's work envelope.

The base of the robot is normally fixed to a stationary work surface. It may, however, be attached to a slidebase, resulting in an extended working range.

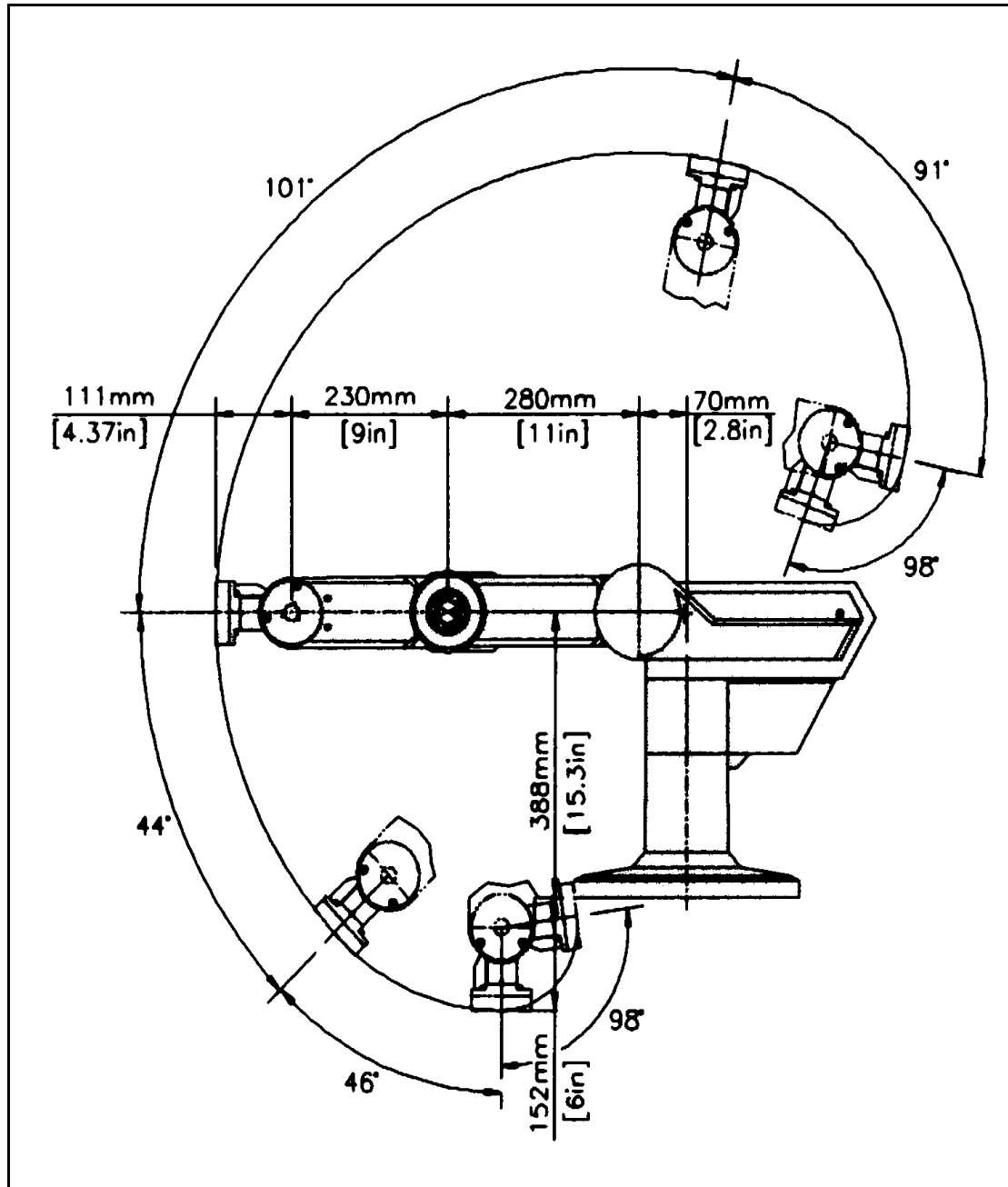

Figure 2-3: Operating Range (Side View)

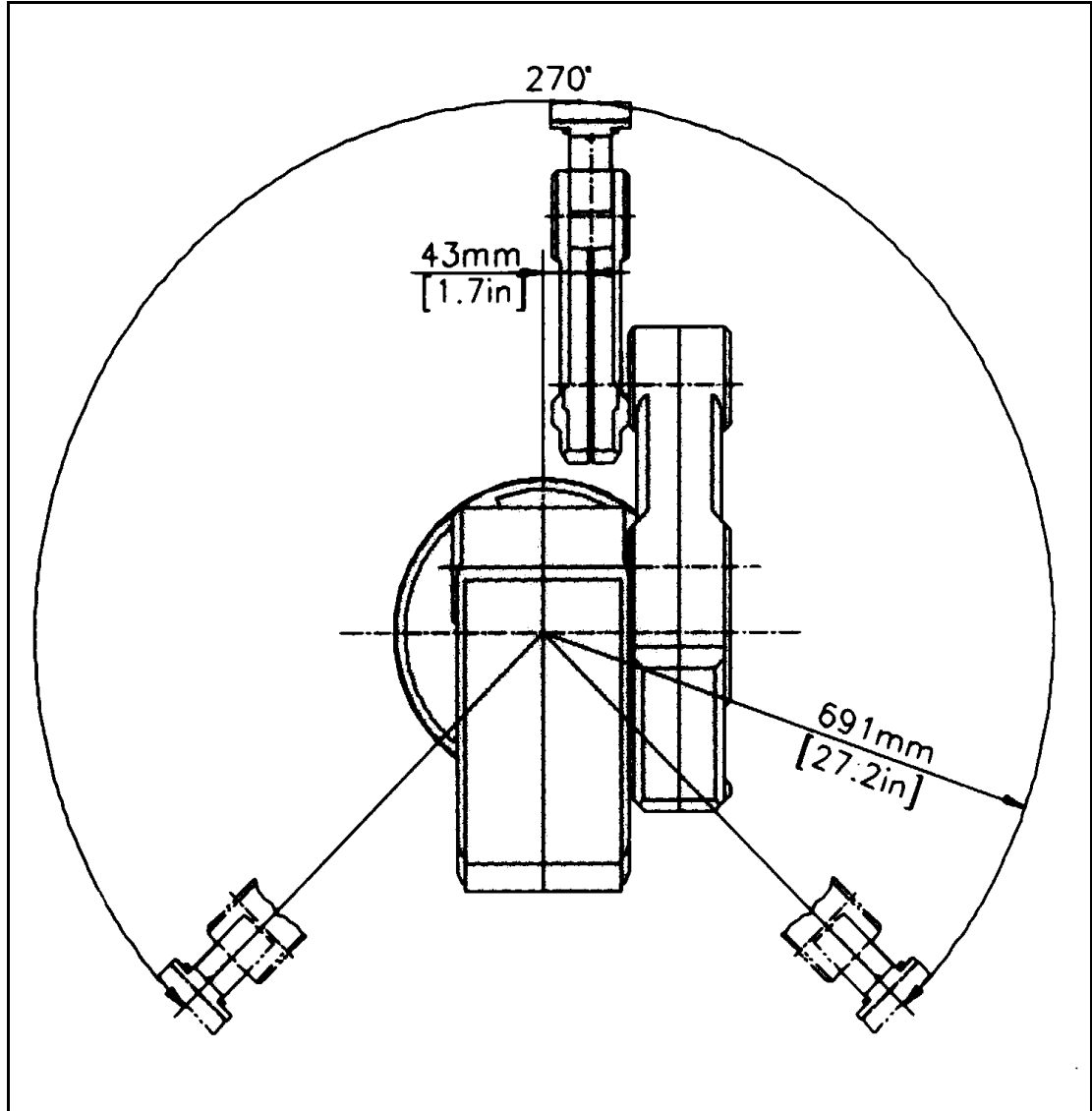

Figure 2-4: Operating Range (Top View)

Safety

The **SCORBOT-ER IX** is a potentially dangerous machine. Safety during operation is of the utmost importance. Use extreme caution when working with the robot.

Precautions

The following chapters of this manual provide complete details for proper installation and operation of the **SCORBOT-ER IX**. The list below summarizes the most important safety measures.

1. Make sure the robot base is properly and securely bolted in place.
2. Make sure the cable from the body to the base can move freely during all movements of the robot's base axis.
3. Make sure both the encoder cable and the robot power cable are properly connected to the controller before it is turned on.
4. Make sure the robot arm has ample space in which to operate freely.
5. Make sure a guardrail or rope has been set up around the **SCORBOT-ER IX** operating area to protect both the operator and bystanders.
6. Do not enter the robot's safety range or touch the robot when the system is in operation.
7. Press the controller's EMERGENCY switch before you enter the robot's operating area.
8. Turn off the controller's POWER switch before you connect any inputs or outputs to the controller.

 *To immediately abort all running programs and stop all axes of motion, do any of the following:*

- *press the teach pendant's EMERGENCY button;*
- *use the ACL command A <Enter>;*
- *press the controller's red EMERGENCY button.*

Warnings

1. Do not operate the **SCORBOT-ER IX** until you have thoroughly studied both this *User's Manual* and the *ACL Controller-B User's Manual*. Be sure you follow the safety guidelines outlined for both the robot and the controller.
2. Do not install or operate the **SCORBOT-ER IX** under any of the following conditions:
 - Where the ambient temperature drops below or exceeds the specified limits.
 - Where exposed to large amounts of dust, dirt, salt, iron powder, or similar substances.
 - Where subject to vibrations or shocks.
 - Where exposed to direct sunlight.
 - Where subject to chemical, oil or water splashes.
 - Where corrosive or flammable gas is present.
 - Where the power line contains voltage spikes, or near any equipment which generates large electrical noises.
3. Do not abuse the robot arm:
 - Do not operate the robot arm if the encoder cable is not connected to the controller.
 - Do not overload the robot arm. The combined weight of the workload and gripper may not exceed 2kg (4.4 lb.). It is recommended that the workload be grasped at its center of gravity.
 - Do not use physical force to move or stop any part of the robot arm.
 - Do not drive the robot arm into any object or physical obstacle.
 - Do not leave a loaded arm extended for more than a few minutes.
 - Do not leave any of the axes under mechanical strain for any length of time. Especially, do not leave the gripper grasping an object indefinitely.

Installation

Preparations

Before you make any cable connections, set up the system components according to the following “Preparation” instructions.

Controller and Computer/Terminal Setup

Place the controller and computer at a safe distance from the robot—well outside the robot’s safety range.

Make sure the setup complies with the guidelines defined in the chapter, “Safety,” in the *ACL Controller-B User’s Manual*.

Robot Setup

Refer to Figures 4-1, 4-2 and 4-3.

1. Set up the **SCORBOT-ER IX** on a sturdy surface with at least one meter of free space all around the robot.
2. Note that the robot cable clamp is located at the midpoint of the robot’s horizontal range. Using this midpoint as a reference, set up the robot so that it faces in the proper direction—towards the application or machine it will serve.
3. Fasten the base of the robot to the work surface with three sets of M8 bolt, washer and nut.

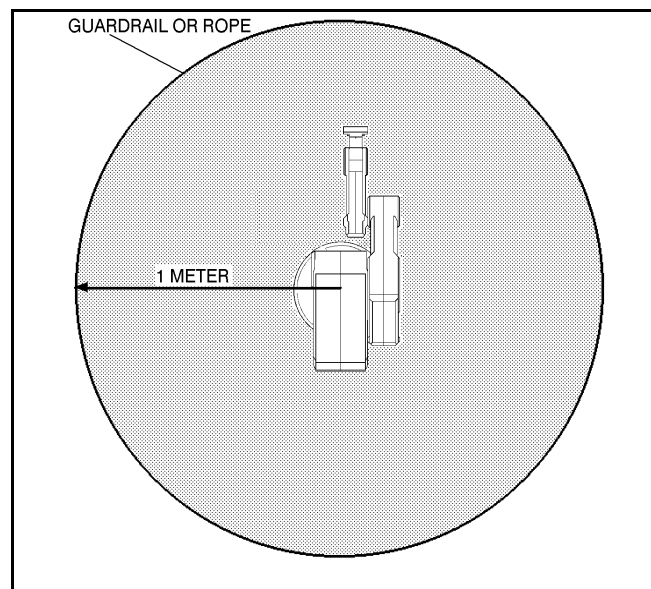



Figure 4-1: Robot Safety Range

Make sure the robot is securely bolted in place. Otherwise the robot could become unbalanced and topple over while in motion.

4. Grasp the robot body and turn the robot to each extreme of its base axis.

 *Make sure the segment of cable from the body to the base is not obstructed, and/or cannot become caught under a corner of the robot's platform or work surface during all movements of the base axis.*

Make sure the robot is mounted on a surface large enough to provide support for this segment of the robot cable during all movements of the base axis.

5. Set up a guardrail or rope around the SCORBOT-ER IX operating area to protect both the operator and bystanders.

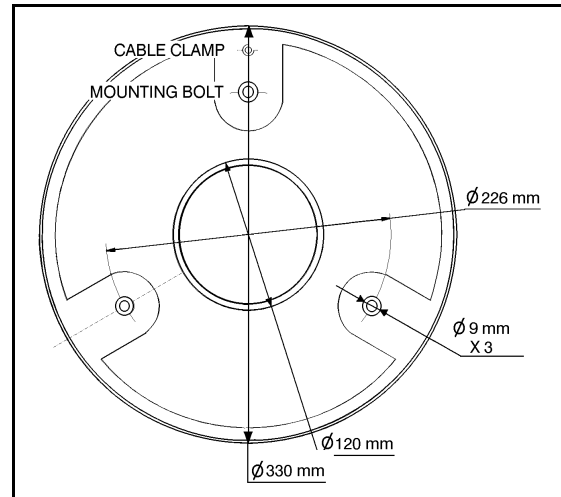

Figure 4-2: Robot Base Layout

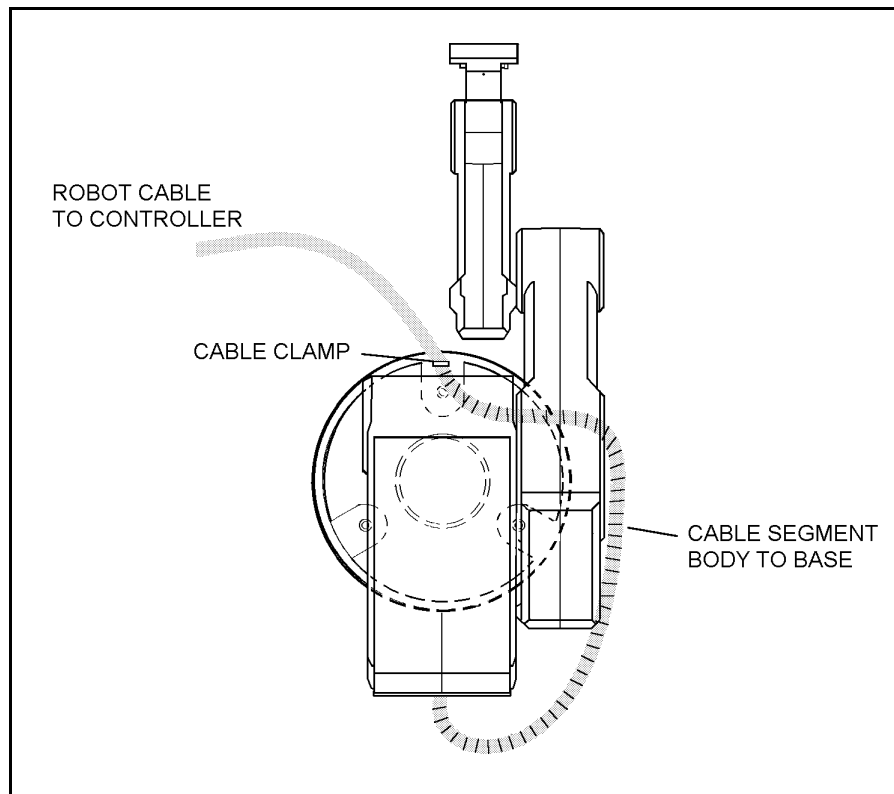

Figure 4-3: Robot Setup

SCORBOT-ER IX Installation

Controller Installation

Perform the installation procedures detailed in the following sections of Chapter 2, “Installation,” in the *Controller-B User’s Manual*:

- **Computer/Terminal–Controller Installation**
- **Power On**
- **Controller Configuration**

☞ When the Peripheral Setup screen appears at the end of the controller configuration, select **Gripper Connection: None**. (You will change this setting after the gripper is installed.) Refer to the section, “Peripheral Devices and Equipment--Robot Gripper,” in the *Controller-B User’s Manual*.

Robot Installation

☞ *Before you begin, make sure the controller POWER switch is turned off.*

The robot cable has a number of connectors. Connect them to the controller according to following three steps. Refer to Figure 4-4.

1. Connect the green/yellow wire to the Safety Ground:
Unscrew and remove the ground nut and washer from the Safety Ground stud. Place the ground wire terminal onto the stud, then replace and tighten the washer and nut.
2. Plug the the D37 connector into the Robot Encoders port.
Tighten the retaining screws on the connector.
3. Plug the 19-pin round connector into the Robot Power port.

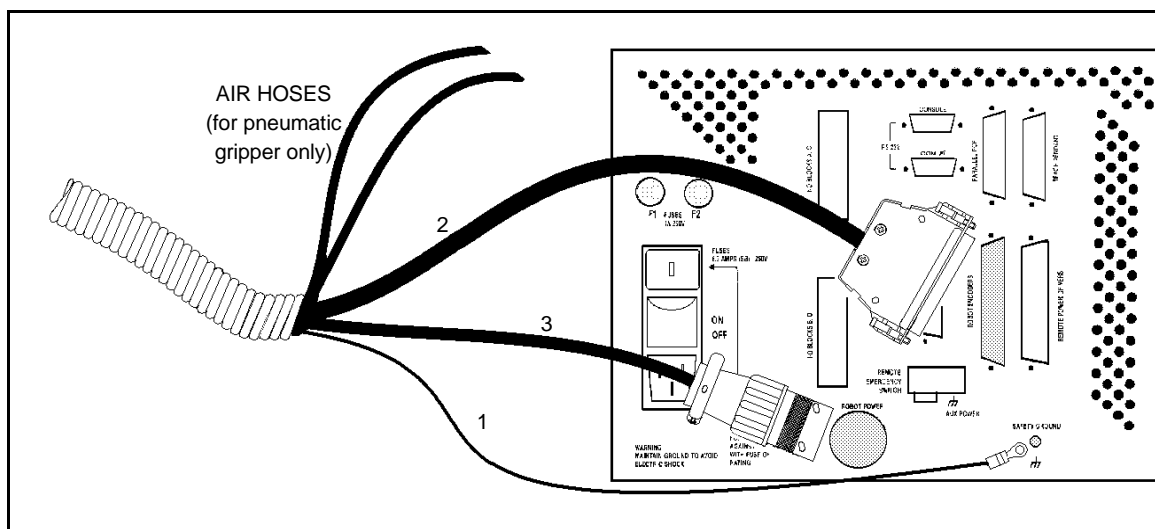



Figure 4-4: Robot—Controller Cable Connections

Note: When disconnecting the robot from the controller, do it in the reverse order; that is:

- Disconnect the 19-pin round Robot Power connector.
- Disconnect the 37-pin Encoders connector.
- Disconnect the ground wires.

Homing the Robot

After you have completed the robot installation, execute the robot's Home routine, as described below.

 *The robot must be homed before you mount the gripper.*

 *Before you begin the homing procedure, make sure the robot has ample space in which to move freely and extend its arm.*

1. Turn on the controller. Turn on the computer.
2. From the ATS diskette or directory, activate the ATS software. Type:

```
ats <Enter>
```

If the controller is connected to computer port COM2, type:

```
ats /c2
```

3. When the ATS screen and > prompt appear, you may proceed.
4. Give the ACL command to home the robot. Type:

```
home <Enter>
```

The monitor will display:

```
WAIT!! HOMING...
```

During the Home procedure, the robot joints move and search for their home positions in the following sequence: shoulder, elbow, pitch, roll, base.

If home is found, a message is displayed:

```
HOMING COMPLETE (ROBOT)
```

If the HOME process is not completed, an error message identifying the failure is displayed. For example:

```
*** HOME FAILURE AXIS 3
```

If the home switch is found, but not the encoder's index pulse, the following message is displayed:

```
* * * INDEX PULSE NOT FOUND AXIS 2
```

Gripper Installation

The gripper is attached to the flange at the end of the robot arm whose layout is shown in Figure 4-5.

Pneumatic Gripper

The pneumatic gripper, shown in Figure 4-6, is controlled by a 5/2 solenoid pneumatic valve which is activated by one of the controller's relay outputs. The valve may be 12VDC or 24VDC and can draw its power from the controller's User Power Supply.

☞ *The robot must be homed before you mount the gripper.*

1. Using a hex wrench and six M4x8 socket screws, attach the gripper to the robot arm flange.
2. Connect the coiled double hose from the gripper to the quick coupling on the robot's forearm, as indicated in Figure 4-7.
3. Refer to Figure 4-8.
 - Connect the two transparent 1/4" O.D. hoses from the robot cable to the CYL ports on the pneumatic valve.
 - Connect a 5 bar/90 PSI air supply to the IN port on the valve.
4. Refer to Figure 4-9.

Connect the valve to the controller's User Power Supply as follows:

- Connect the black wire to a common terminal.
 - Connect the red wire to the normally open (NO) terminal of any unused relay output.
5. Connect 12VDC or 24VDC (in accordance with your valve's specification) to the common (C) terminal of the **same** relay output, as shown in Figure 4-9.

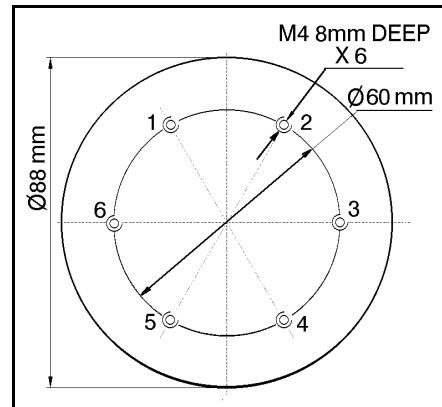

Figure 4-5: Gripper Mounting Flange Layout

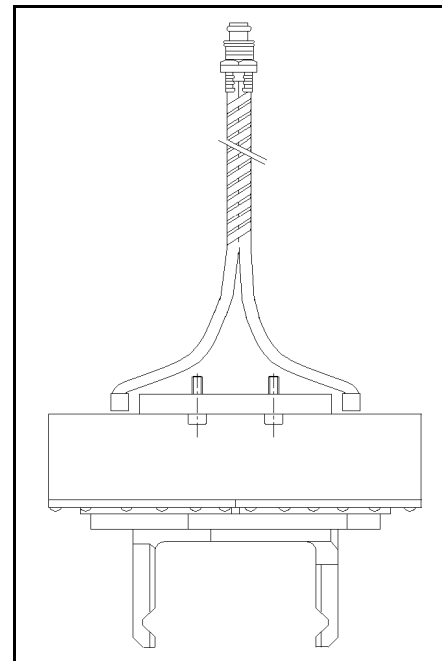

Figure 4-6: Pneumatic Gripper

6. Attach the valve to the controller or any other metallic surface by means of the valve's magnetic base.

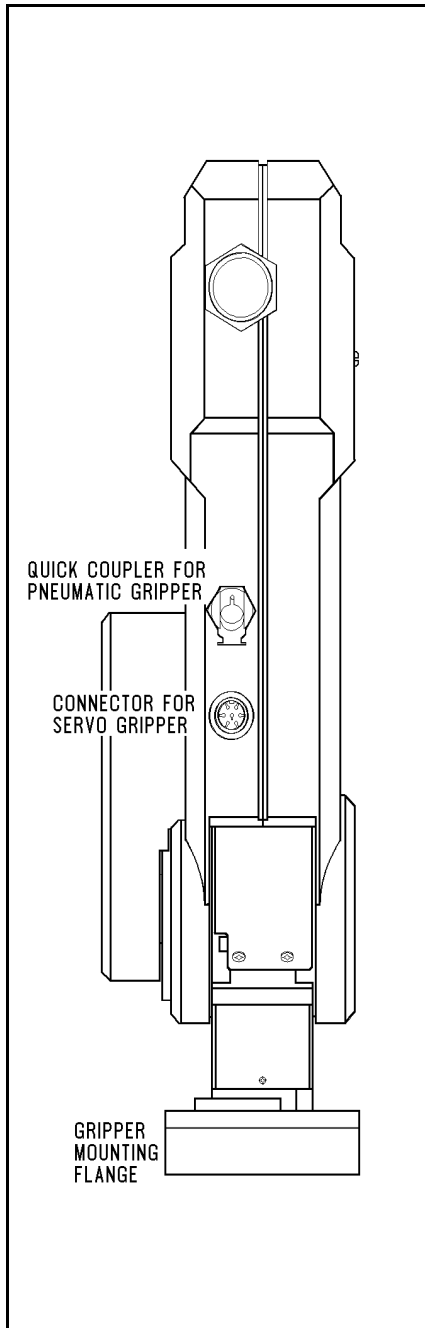

Figure 4-7:
Gripper Connectors

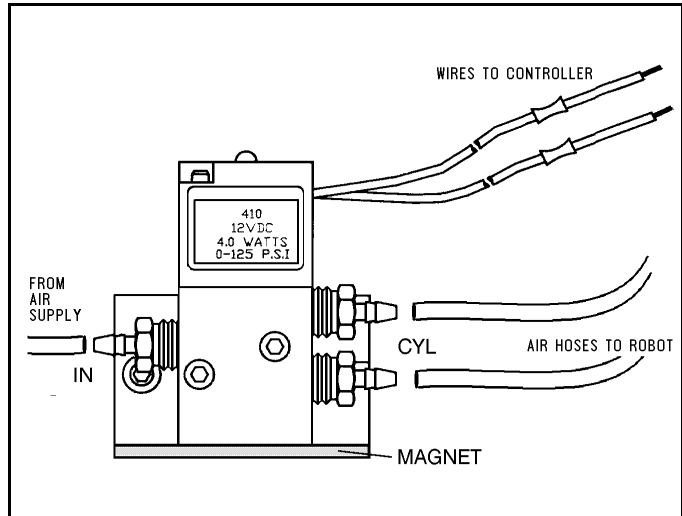

Figure 4-8: Pneumatic Solenoid Valve

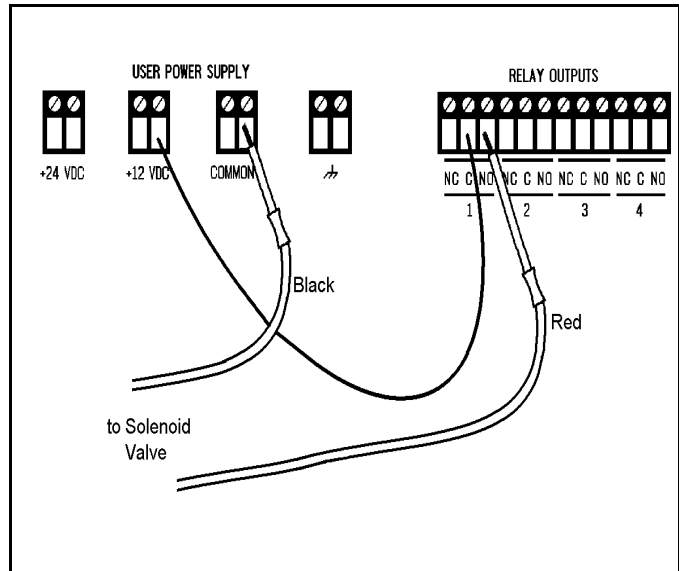



Figure 4-9: Valve—Controller Connections

DC Servo Gripper

The electric DC servo gripper is shown in the inset in Figure 4-10.

 *The robot must be homed before you mount the gripper.*

Refer to Figures 4-10 and 4-11.

1. Using a 3 mm hex wrench and four M4x10 socket screws, attach the gripper to the gripper mounting flange at the end of the robot arm.
2. Connect the gripper cable to the electrical connector on the robot arm. Make sure the connector is oriented as shown in Figure 4-10.
3. Make sure the gripper cable is positioned as shown in Figure 4-11.
4. Carefully execute the robot HOME command. Stay close to the teach pendant or controller. If the gripper cable becomes entangled or excessively stretched during the homing, abort the procedure immediately.
5. The gripper has a rotation of $\pm 270^\circ$. Do not attempt to move the gripper beyond this limit.
6. At the end of each work session (before turning off the controller), or before homing the robot, make sure the gripper's position is as shown in Figure 4-11.

 *Axis 6 is reserved by default controller configuration for a servo gripper. To connect a different device as axis 6, you must change the system configuration by means of the ACL command CONFIG.*

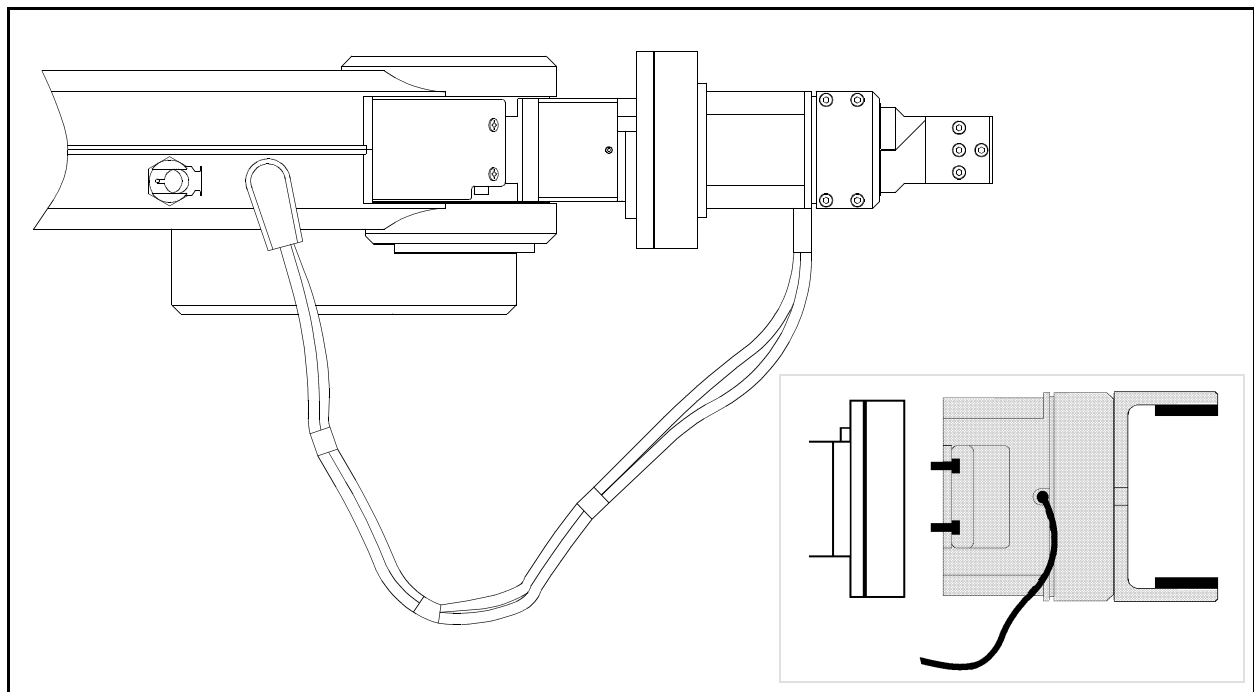

Figure 4-10: Connecting Gripper to SCORBOT-ER IX

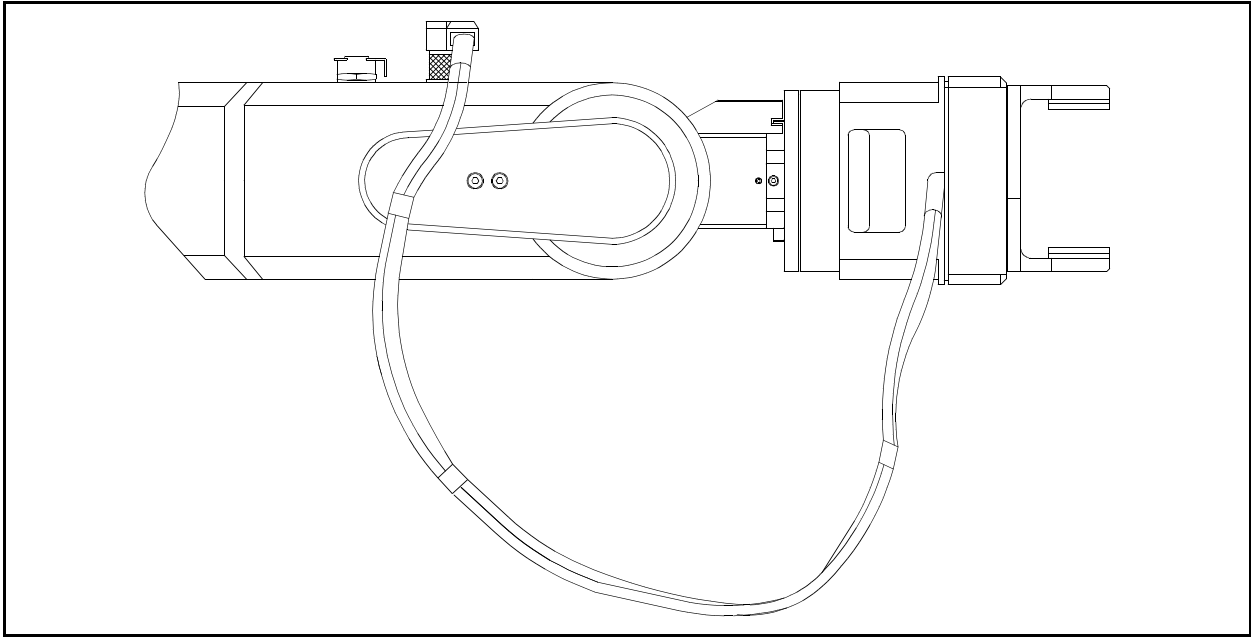

Figure 4-11: Connecting Gripper to SCORBOT-ER IX

Activating the Gripper

1. Activate **ATS**. Press <Ctrl>+F3 to activate the Peripheral Setup screen.
2. Change the robot gripper definition according to the gripper you have installed. Refer to the section, “Peripheral Devices and Equipment--Robot Gripper,” in Chapter 2 of the *ACL Controller-B User’s Manual*.
3. Open and close it in order to verify that it is functioning. The following commands work for both the electric and the pneumatic gripper.

PC

Type:

```
open <Enter>
```

The gripper opens.

Type:

```
close <Enter>
```

The gripper closes.

TP

Key in:

Open/Close

The Open/Close key toggles the gripper between its open and closed states. programs you have just written.

Operating Methods

The **SCORBOT-ER IX** robot can be programmed and operated in a number of ways.

The *ACL Controller-B User's Manual* includes two chapters which guide you through the basic commands for operating and programming the robot.

Software

ACL

ACL, Advanced Control Language, is an advanced, multi-tasking robotic programming language developed by Eshed Robotec. **ACL** is programmed onto a set of EPROMs within **Controller-B**, and can be accessed from any standard terminal or PC by means of an RS232 communication channel.

ACL features include the following:

- Direct user control of robotic axes.
- User programming of robotic system.
- Input/output data control.
- Simultaneous and synchronized program execution (full multi-tasking support).
- Simple file management.

The *ACL Reference Guide for Controller-B* provides detailed descriptions and examples of the **ACL** commands and functions.

ATS

ATS, Advanced Terminal Software, is the user interface to the **ACL** controller. **ATS** is supplied on diskette and operates on any PC. The software is a terminal emulator which enables access to the **ACL** environment from a PC host computer.

ATS features include the following:

- Short-form controller configuration.
- Definition of peripheral devices.
- Short-cut keys for command entry.
- Program editor.
- Backup manager.
- Print manager.

The *ATS Reference Guide for Controller-B* is a complete guide to **ATS**.

ACLoff-line

ACLoff-line is a preprocessor software utility, which lets you access and use your own text editor to create and edit **ACL** programs even when the controller is not connected or not communicating with your computer.

After communication is established, the **Downloader** utility lets you transfer your program to the controller. The Downloader detects the preprocessor directives, and replaces them with a string or block of **ACL** program code.

ACLoff-line also enables activation of **ATS**, Advanced Terminal Software, for on-line programming and system operation.

ACLoff-line is described fully in the *ACLoff-line User's Manual*.

SCORBASE Software

SCORBASE Level 5 is a robot control software package which is supplied on diskette with the controller. Its menu-driven structure and off-line capabilities facilitate robotic programming and operation.

SCORBASE runs on any PC system and communicates with **ACL**, the controller's internal language, by means of an RS232 channel.

The *SCORBASE Level 5 for Controller-B Reference Guide* provides detailed descriptions and examples of the **SCORBASE** commands.

Teach Pendant

The teach pendant is a hand-held terminal which is used for controlling the **SCORBOT-ER IX** robot and peripheral equipment. The teach pendant is most practical for moving the axes, recording positions, sending the axes to recorded positions and activating programs. Other functions can also be executed from the teach pendant.

The *Teach Pendant for Controller-B User's Manual* fully describes the various elements and functions of the teach pendant.

Drive System

The three main elements of the SCORBOT-ER IX drive system are shown in Figure 6-1:

- DC electrical motor
- Harmonic Drive gear
- Timing belt and pulleys

Figure 6-1 shows the drive system for axes 1 through 4 of the SCORBOT ER-IX. The roll axis (axis 5) transmission does not contain the pulleys and timing belt; only a Harmonic Drive is used.

Note that the illustrations of components shown in this chapter are for descriptive purposes, and may not be the actual components used in the SCORBOT-ER IX.

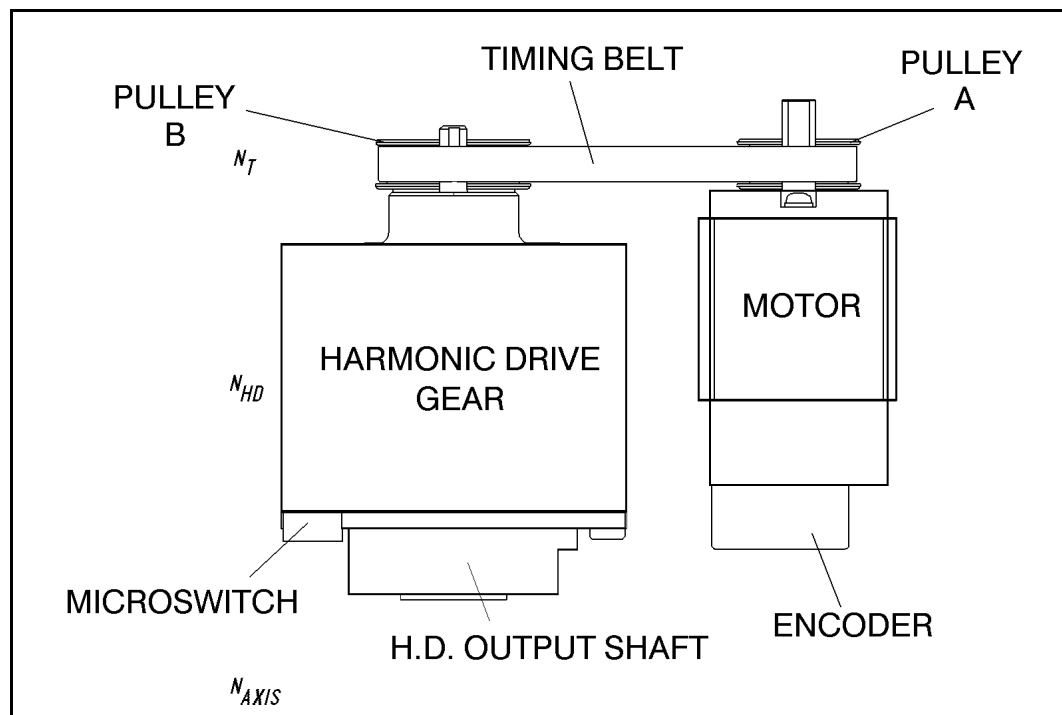

Figure 6-1: The SCORBOT-ER IX Drive System

Motors

The **SCORBOT-ER IX** robot arm is driven by DC electric motors. These actuators convert signals from the controller (electric power) into rotations of the motor shaft (mechanical power).

A robot arm such as the **SCORBOT-ER IX** imposes severe requirements on the actuators, such as the following:

- The robot motor must rotate at different speeds, and with a high degree of accuracy. For example, if the robot is to be used for a spray painting application, it must be able to accurately follow the defined path at the specified speed.
- The robot motor must allow fine speed regulation so that the robot will accelerate and decelerate as required by the application.
- The robot motor must supply large torques throughout its speed range and also when the joint is stationary.
- The robot motor must be able to stop extremely quickly without overshooting the target position, and perform rapid changes in direction.
- Since mounting motors on the robot arm adds to the robot's weight and inertia, the robot motors must be light and compact, yet powerful. As shown in Figure 6-2, the motors of the **SCORBOT-ER IX** are located on the axes they drive, with a two-stage (axes 1–4) or one-stage (axis 5) transmission.

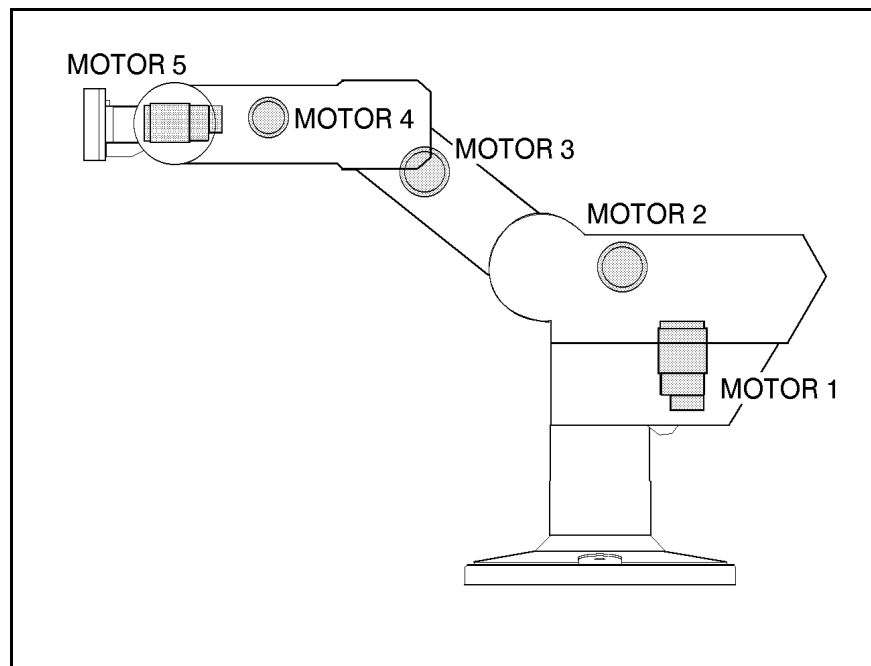

Figure 6-2: Motor Locations in SCORBOT-ER IX

DC Motor Structure

The principles of operation of electrical motors in general, and DC motors in particular, are based on an electrical current flowing through a conductor situated within a magnetic field. This situation creates a force which acts on the conductor.

Figure 6-3 shows the basic structure and components of a DC motor comparable to the structure of the motors used in the **SCORBOT-ER IX**. This motors has three main components:

- **Stator:** This is a static component which creates the magnetic field. The stator may be a permanent magnet, or an electromagnet consisting of a coil wound around thin iron plates.
- **Rotor:** This is the component which rotates within the magnetic field. The external load is connected to the rotor shaft. The rotor is generally composed of perforated iron plates, and a conducting wire is wound several times around the plates and through the perforations. The two ends of the conductor are connected to the two halves of the commutator, which are connected to the electric current via the brushes.
- **Brushes:** These connect the rotating commutator to the electric current source.

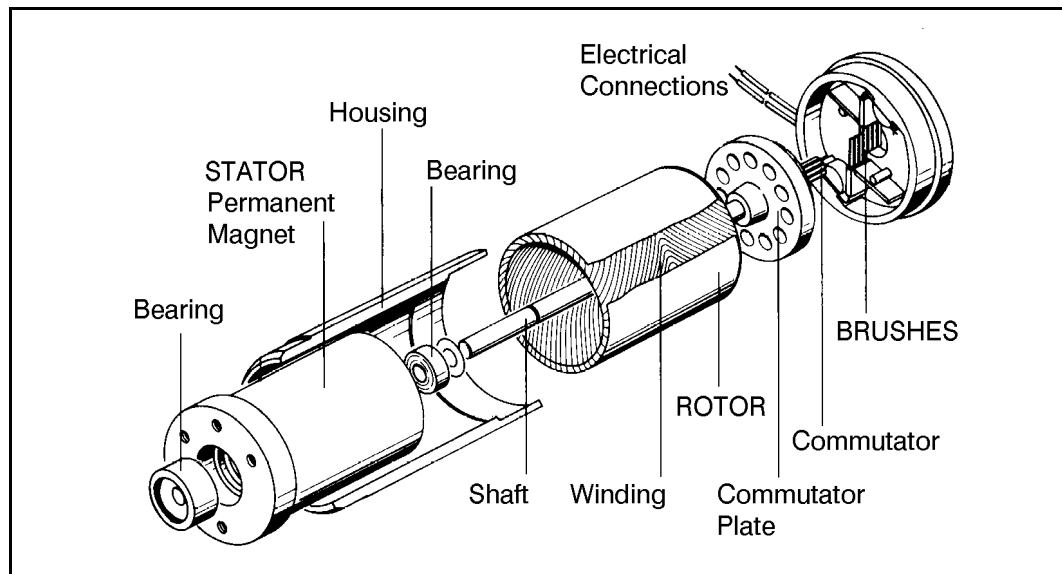

Figure 6-3: Basic Structure of a DC Motor

SCORBOT-ER IX Motors

The SCORBOT ER-IX uses permanent magnet DC motors to drive the axes.

Axes 1, 2 and 3 of the SCORBOT ER-IX are powered by the motor shown in Figure 6-4. Axes 4 and 5 are powered by the motor shown in Figure 6-5.

These motors are able to move at extremely high rates of revolution, to move loads with high torques, and (with encoder attached) to achieve a very high resolution.

Motor Specifications		
	Motor Axes 1, 2, 3	Motor Axes 4, 5
Peak Rated Torque	143 oz-in	27.8 oz-in
Rated Torque	32 oz-in	12.5 oz-in
Maximum Operating Speed	4000 rpm	4500 rpm
Weight	1.29 k / 2.84 lb	0.28 k / 0.62 lb

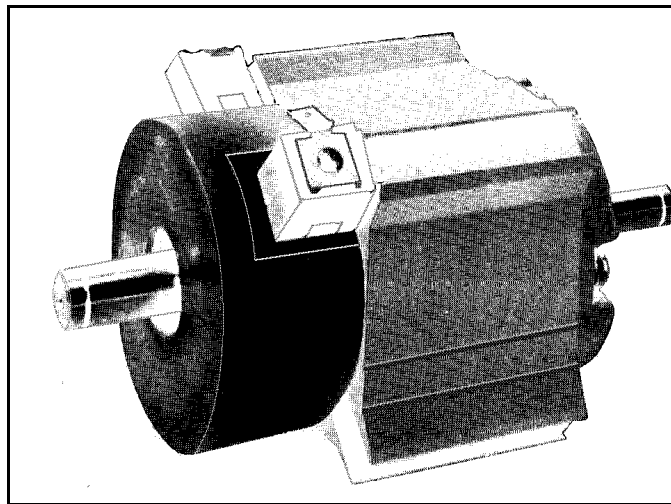

Figure 6-4: Motor on Axes 1, 2 and 3

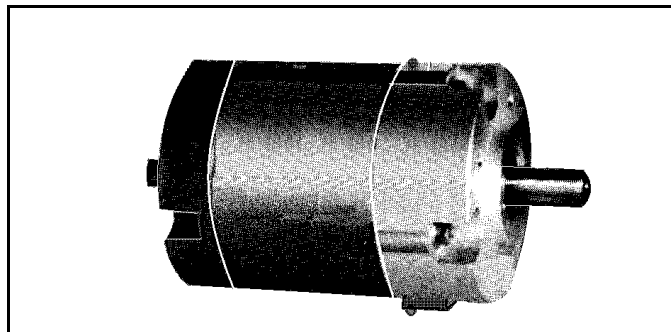

Figure 6-5: Motor on Axes 4 and 5

Harmonic Drive Gears

The Harmonic Drive transmission used in the **SCORBOT-ER IX**, shown in Figure 6-6, offers a very high gear ratio.

The Harmonic Drive gears used in the **SCORBOT-ER IX** have four main components:

- **Circular spline:**
a solid steel ring, with internal gear teeth, usually fixed to the robot link.
- **Wave generator:**
a slightly elliptical rigid disk, which is connected to the input shaft, with a ball bearing mounted on the outer side of the disk.
- **Flexspline:**
a flexible, thin-walled cylinder, with external gear teeth, usually connected to the output shaft.
- **Dynamic spline:** a solid steel cylinder, with internal gear teeth.

The external gear teeth on the flexspline are almost the same size as the internal gear teeth on the circular spline except there are two more teeth on the circular spline, and the teeth only mesh when the wave generator pushes the flexspline outwards.

Because the wave generator is elliptical, the flexspline is pushed out in two places. As the motor rotates the input shaft, the wave generator rotates and the location of meshing teeth rotates with it. However, because there are two less teeth on the flexspline, it has to rotate backwards slightly as the wave generator rotates forwards. For each complete rotation of the input shaft, the flexspline moves backwards by two teeth.

Figures 6-7 and 6-8 show the different steps in this process.

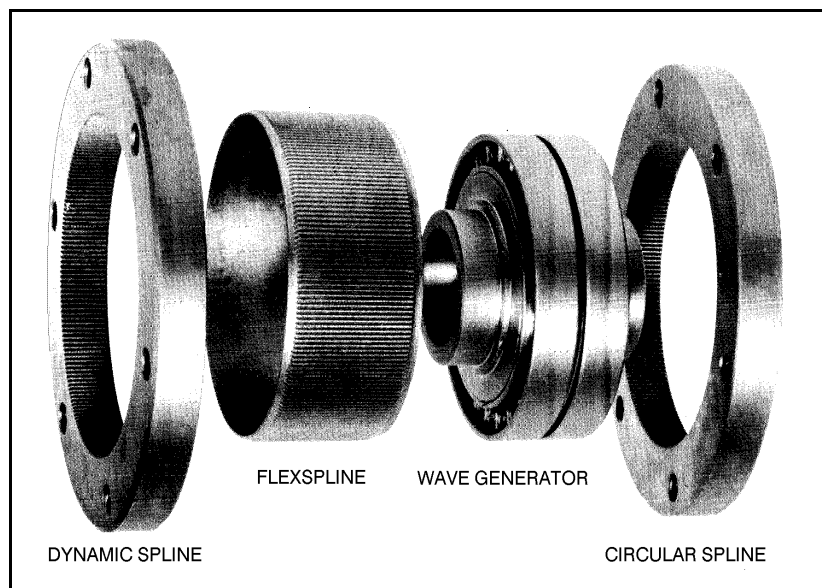

Figure 6-6: Harmonic Drive Structure

Harmonic Drive Gear Ratios

As in all gears, the gear ratio of the Harmonic Drive is the ratio of the input speed to the output speed. If the number of teeth on the flexspline is N_f , then for every revolution of the input shaft, the output shaft rotates by $2/N_f$ of a revolution (that is, two teeth out of N_f teeth). Hence:

$$HD \text{ gear ratio} = \frac{1}{\left(\frac{2}{N_f}\right)} = \frac{N_f}{2}$$

The Harmonic Drive gear ratios for each of the **SCORBOT-ER IX** axes are as follows:

- Axis 1 — 161:1
- Axis 2 — 160:1
- Axis 3 — 160:1
- Axis 4 — 100:1
- Axis 5 — 100:1

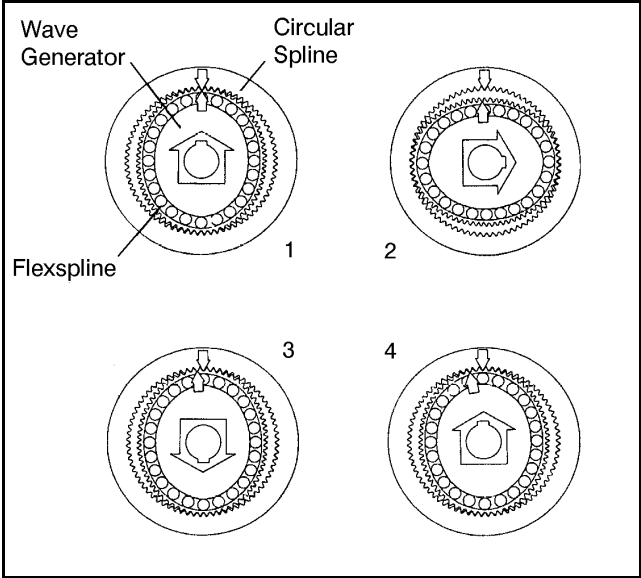

Figure 6-7: Operation of the Harmonic Drive

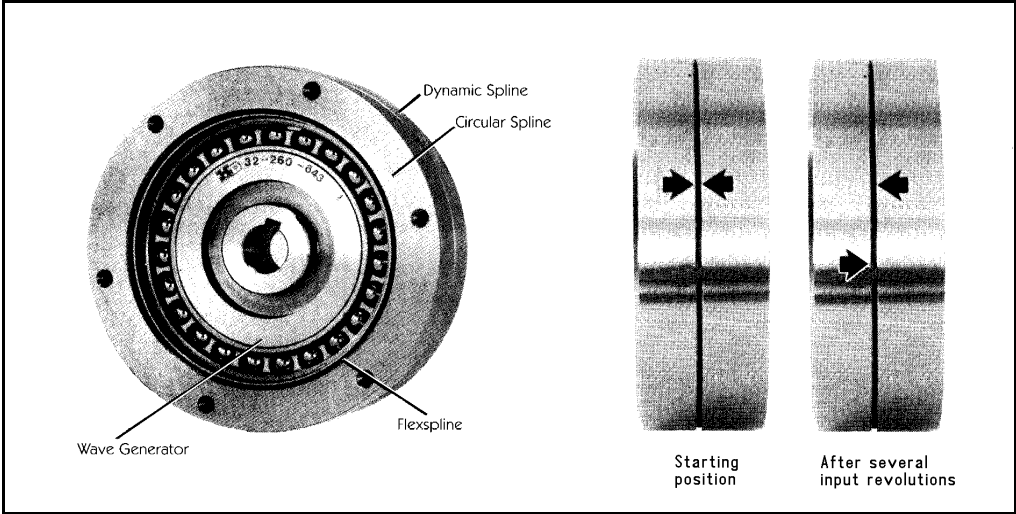

Figure 6-8: Operation of the Harmonic Drive

Axis Gear Ratios

Referring again to Figure 6-1, the transmission of axes 1 through 4 consists of two stages: the timing belt drive, and the Harmonic Drive.

The overall gear ratio of the output shaft which moves the axis is therefore expressed as:

$$N_T \times N_{HD} = N_{AXIS}$$

Where:

N_T is the belt drive ratio (that is, the radii ratio): $\frac{\text{Pulley B}}{\text{Pulley A}}$

N_{HD} is the Harmonic drive ratio, as described above.

N_{AXIS} is the overall gear ratio of the axis.

SCORBOT-ER IX Gear Ratios			
	N_T	N_{HD}	N_{AXIS}
Axis 1	1.33 : 1	161 : 1	214.13 : 1
Axis 2	1.52 : 1	160 : 1	243.8 : 1
Axis 3	1.33 : 1	160 : 1	213.33 : 1
Axis 4	1.8 : 1	100 : 1	180 : 1
Axis 5		100 : 1	100 : 1

Thus, one rotation (360°) of axis 3, for example, requires 213.33 rotations of the motor shaft. The actual movement of the axis, however, is limited by the arm's mechanical structure.

This page intentionally left blank.

Position and Limit Devices

This chapter describes the various elements in the **SCORBOT-ER IX** which play a part in the positioning of the robot arm and the limiting of its motion.

- Encoders
- End of Travel Switches
- Hard Stops
- Home Switches

Encoders

The location and movement of each **SCORBOT-ER IX** axis is measured by an electro-optical encoder attached to the motor which drives the axis. The encoder translates the rotary motion of the motor shaft into a digital signal understood by the controller.

Figure 7-1 shows the encoder mounted on a **SCORBOT-ER IX** motor.

The encoder used on the **SCORBOT-ER IX** contains a single light emitting diode (LED) as its light source. Opposite the LED is a light detector integrated circuit. This IC contains several sets of photodetectors and the circuitry for producing a digital signal. A perforated, rotating disk is located between the emitter and detector IC.

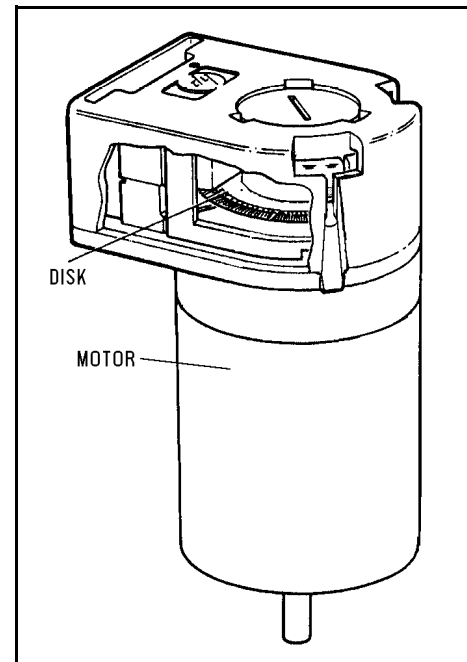

Figure 7-1:
SCORBOT-ER IX Encoder

As the encoder disk rotates between the emitter and detectors, the light beam is interrupted by the pattern of “bars” and “windows” on the disk, resulting in a series of pulses received by the detectors.

The SCORBOT-ER IX encoders have 512 slots, as shown in Figure 7-2. An additional slot on the encoder disk is used to generate an index pulse (C-pulse) once for each full rotation of the disk. This index pulse serves to determine the home position of the axis.

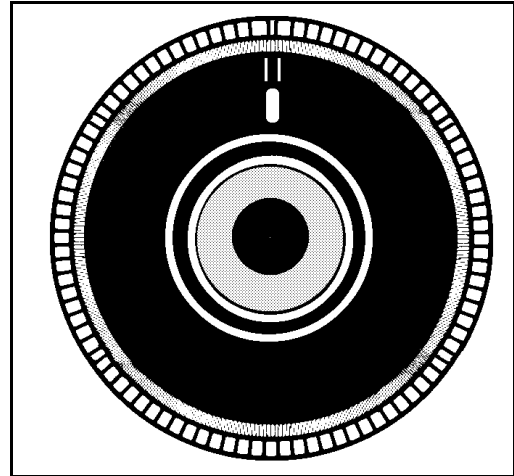

Figure 7-2:
SCORBOT-ER IX Encoder Disk

The photodetectors are arranged so that, alternately, some detect light while others do not. The photodiode outputs are then fed through the signal processing circuitry, resulting in the signals A, \bar{A} , B, \bar{B} , I and \bar{I} , as shown in Figure 7-3.

Comparators receive these signals and produce the final digital outputs for channels A, B and I. The output of channel A is in quadrature with that of channel B (90° out of phase), as shown in Figure 7-4. The final output of channel I is an index pulse.

When the disk rotation is counterclockwise (as viewed from the encoder end of the motor), channel A will lead channel B. When the disk rotation is clockwise, channel B will lead channel A.

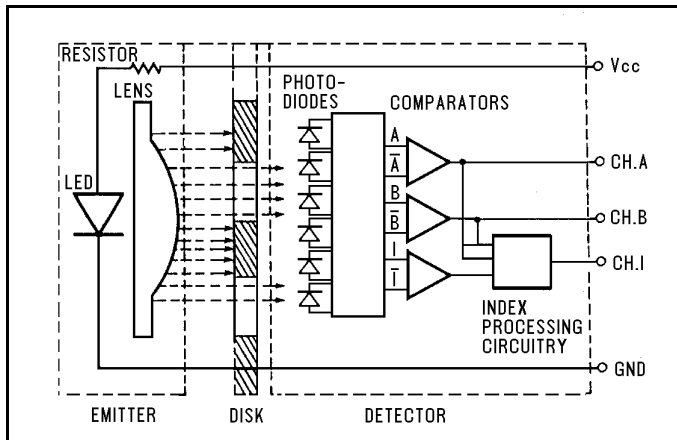

Figure 7-3: Encoder Circuitry

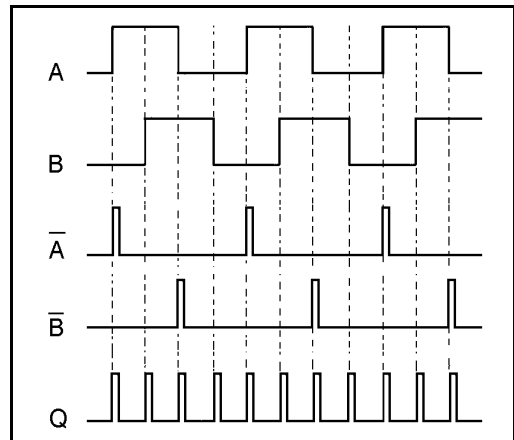

Figure 7-4: Encoder Output Signals

Encoder Resolution

From the quadrature signal the **SCORBOT-ER IX** controller measures four counts for each encoder slot, thus quadrupling the effective resolution of the encoder.

The resolution of the encoder is expressed as:

$$S_E = \frac{360^\circ}{n}$$

Where:

S_E is the resolution of the encoder.

n is the number of counts per encoder revolution.

The encoders used in the **SCORBOT-ER IX** have 512 slots, generating 2048 counts per motor revolution. The encoder resolution is therefore:

$$S_E = \frac{360^\circ}{2048} = .176^\circ$$

When the encoder resolution is divided by the overall gear ratio of the axis, the resolution of the joint is obtained.

Since the encoder is mounted on the motor shaft, and turns along with it, the resolution of the joint is expressed as:

$$S_{JOINT} = \frac{S_E}{N_{AXIS}}$$

Thus, for example, the resolution of joint 3 of the **SCORBOT-ER IX** is therefore as follows:

$$S_{J3} = \frac{0.176^\circ}{213.33} = 0.000825^\circ$$

The resolution is the smallest possible increment which the control system can identify and theoretically control. The accuracy of the axis—that is, the precision with which it is positioned—is affected by such factors as backlash, mechanical flexibility, and control variations.

End of Travel (Limit) Switches

The SCORBOT-ER IX uses limit switches to prevent the joints from moving beyond their functional limits. When a control error fails to stop the axis at the end of its working range, the limit switch serves to halt its movement. The switch is part of an electric circuit within the robot arm, independent of the robot controller.

The limit switches used in the SCORBOT-ER IX are shown in Figure 7-5.

Each of axes 1 through 4 has two limit switches: one at each end of the axis' working range.

Axis 5 (roll) has no travel limit switches; it can rotate endlessly. When a gripper is attached to axis 5, its movements are controlled and limited by means of software only (encoder).

The limit switches are mounted on a disk which is attached to the robot's frame. The disk for axis 3 is shown in Figure 7-6.

The output shaft of the Harmonic Drive moves relative to the microswitch disk.

As the joint moves, a cam on the Harmonic Drive output shaft reaches a point at which it forces the actuating button of the limit switch into a position which activates the switch.

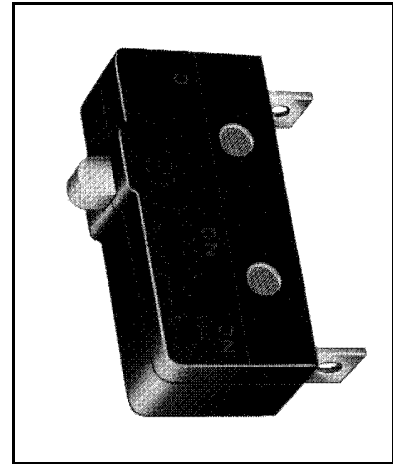

Figure 7-5:
SCORBOT-ER IX
Limit Switch

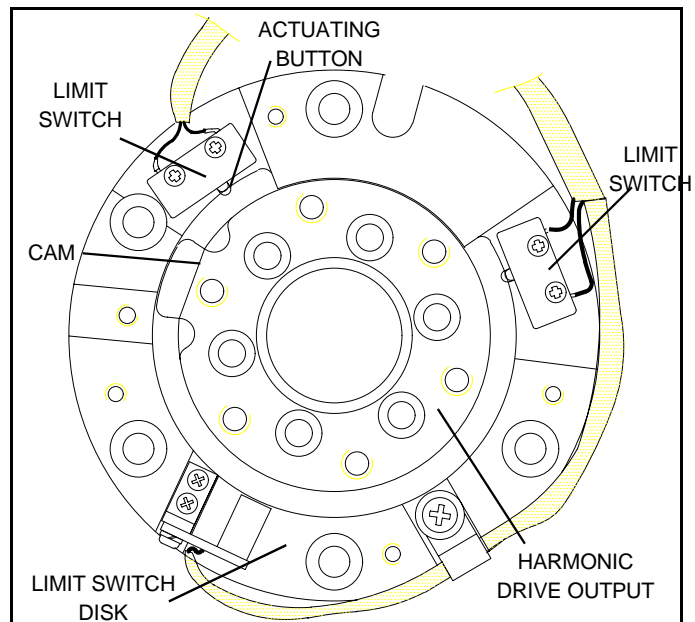

Figure 7-6: Limit Switch Activation

As shown in Figure 7-7A, when limit switch 1 is activated (that is, when the button is depressed), the relay contact opens and the relay is deenergized. The motor cannot move the joint beyond this point. The diode allows the motor to reverse direction, thus permitting the joint to move away from the limit switch.

When the limit switch is activated, it causes a control error, resulting in the activation of COFF (control off mode), and an impact protection message.

CON (control on mode) must be activated and the robot arm must be manually moved (using keyboard or teach pendant) away from the impact condition.

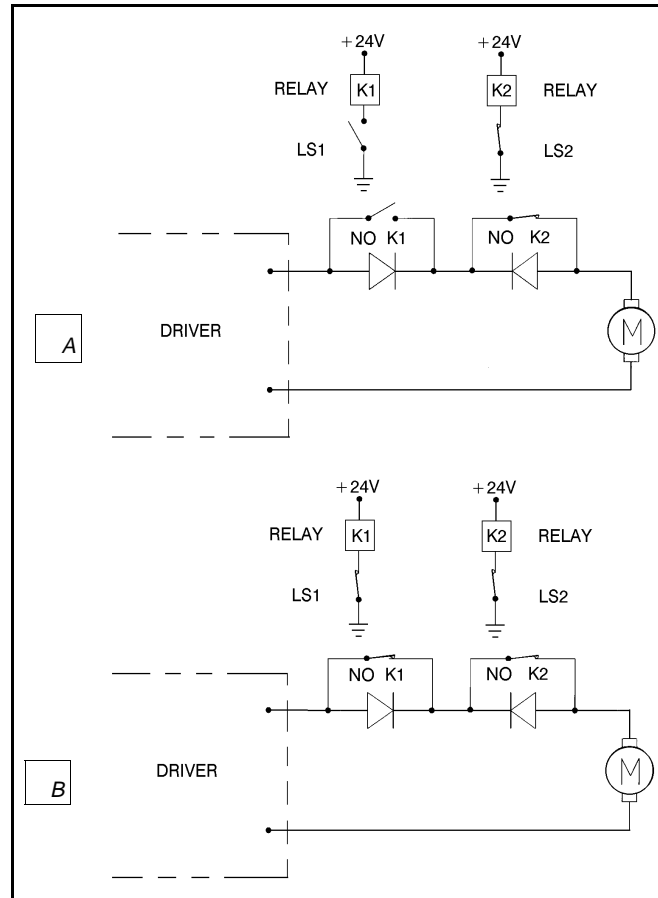

Figure 7-7: Axis Limit Circuit

As long as the axis has not reached one of its limits, the relay contact remains closed, and the diode has no effect on the circuit, as shown in Figure 7-7B. Current can flow in either direction; the motor is thus able to rotate in either direction.

Hard Stops

When the software limits and/or the end of travel switches fail to halt the movement of the robot arm, it is possible that the momentum of the robot arm will drive it until it reaches its mechanical limit.

When the joint reaches this hard stop, the impact protection and thermic protection processes detect an error, thus activating COFF.

CON must be activated and the robot arm must be manually moved away from the impact condition.

Home Switches

The SCORBOT-ER IX uses an optical home switch on each axis to identify the fixed reference, or home, position.

The home switch is mounted on the same disk as the end of travel switches, and a “flag” is attached to the Harmonic Drive output shaft, as shown in Figure 7-8.

During the homing procedure, the robot joints are moved, one at a time. Each axis is moved until the flag cuts the beam of light. When that occurs, the optical detector on each joint sends a specific signal to the controller.

Once the home switch location has been detected, the axis motor continues to rotate until its encoder produces an index pulse. The point at which that occurs is the axis home position.

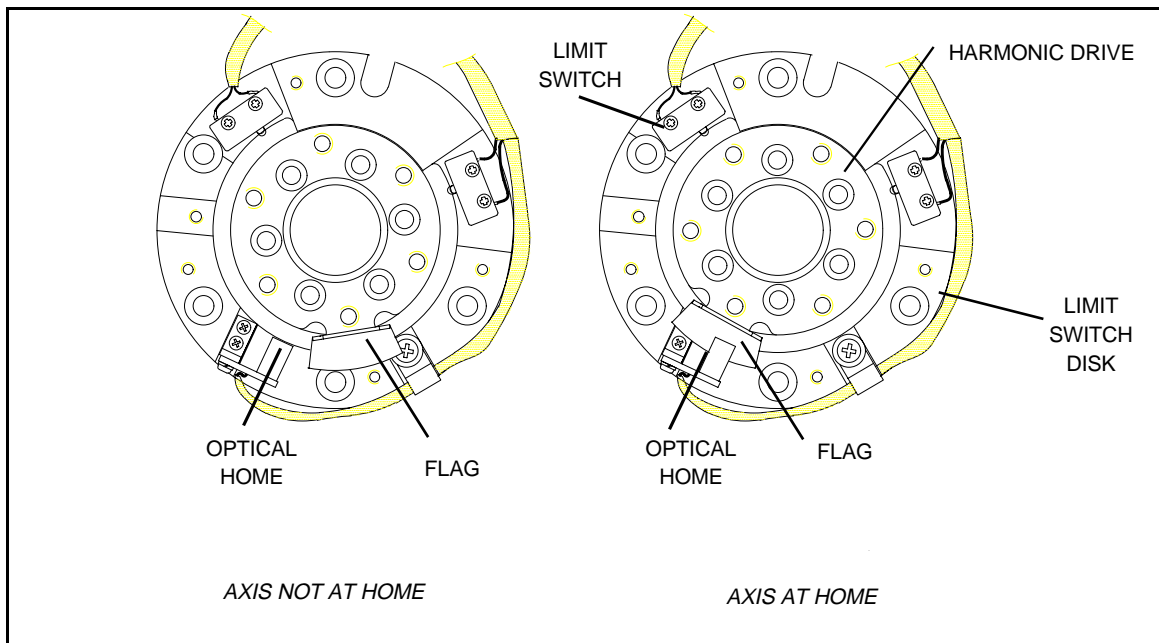

Figure 7-8: Home Switch Activation

Wiring

Figure 9-1 is a schematic diagram of the SCORBOT-ER IX cable connections.

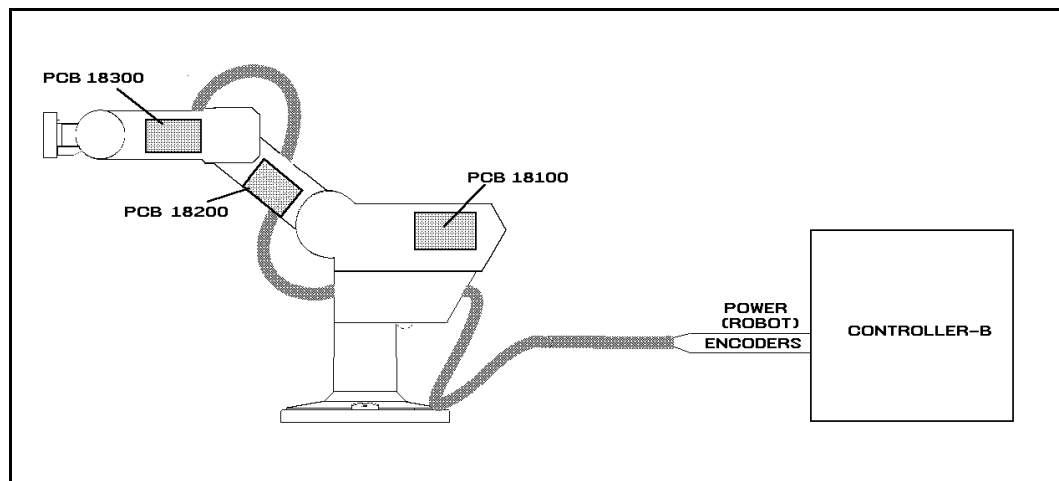

Figure 8-1: SCORBOT-ER IX Cabling

The wire braid which connects the robot to the controller contains a power (robot) cable and an encoder cable.

The body, upper arm and forearm links each contain a printed circuit board (PCB). The motors, encoders, limit switches and home switches for each axis are directly connected to one of these three internal PCBs. Two wire braids connect the PCBs. Each PCB transfers power to the motors to which it is directly connected, and receives signals from the corresponding limit and home switches. When a limit switch is triggered, the PCB automatically cuts off power to the motor that drives the axis. In addition, each PCB transfers power to the next PCB and sends encoder and home switch signals to the previous PCB.

The robot and encoder cable are directly connected to PCB 18100. The robot cable supplies power to the PCB and the encoder cable carries information from the encoders and the home switches for all six axes to the controller.

Robot (Power) Cable and Connector

Figure 8-2 shows the Burndy 19 pin male connector that joins the power cable to the controller's back panel.

The robot cable contains 12 leads. The following table details the connector pin functions and cable wiring.

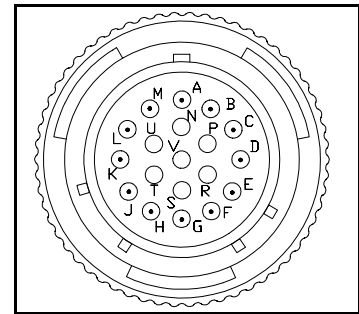

Figure 8-2: Burndy 19 Pin Connector

Robot (Power) Cable Wiring and Connector			
Pin ID	Pin Description Robot Side (J1)	Beldan Color	Pin Description Controller Side (P1)
A	Motor 1 -	black	M0_A
M	Motor 1 +	red	M0_B
C	Motor 2 -	brown	M1_A
L	Motor 2 +	orange	M1_B
E	Motor 3 -	yellow	M2_A
H	Motor 3 +	purple	M2_B
B	Motor 4 -	light blue	M3_A
K	Motor 4 +	blue	M3_B
D	Motor 5 -	grey	M4_A
J	Motor 5 +	pink	M4_B
F	Motor 6 -	white	M5_A
G	Motor 6 +	green	M5_B

Encoder Cable and Connector

The encoder cable, which connects the controller to the motor encoders and optical home switches, contains 36 leads.

Figure 8-3 shows the D37 female connector that joins the encoder cable to the controller's back panel.

The following table details the connector pin functions and describes the cable wiring.

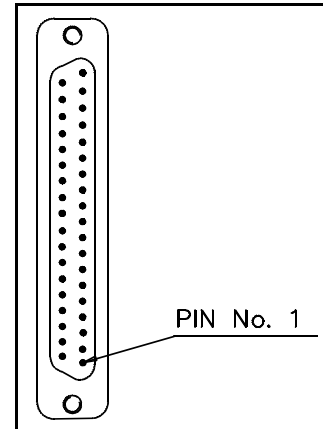

Figure 8-3:
D37 Connector

Encoder Cable and D37 Connector				
Pin ID	Pin Description Robot Side (J1)	Axis	Telephone Cable Color	Pin Description Controller Side (J2)
1	+5V	1	red	+5V
8	COMMON		yellow	COMMON 0
5	CHA1 (Encoder Pulse A)		green	CHA 0
6	CHB1 (Encoder Pulse B)		white	CHB 0
7	CHC1(Encoder Index Pulse)		black	CHC 0
31	MSWITCH (Home Switch)		blue	MSWITCH
1	+5V	2	red	+5V
12	COMMON		yellow	COMMON 1
9	CHA2 (Encoder Pulse A)		green	CHA 1
10	CHB2 (Encoder Pulse B)		white	CHB 1
11	CHC2 (Encoder Index Pulse)		black	CHC 1
32	MSWITCH (Home Switch)		blue	MSWITCH
1	+5V	3	red	+5V
16	COMMON		yellow	COMMON 2
13	CHA3 (Encoder Pulse A)		green	CHA 2
14	CHB3 (Encoder Pulse B)		white	CHB 2
15	CHC3 (Encoder Index Pulse)		black	CHC 2
33	MSWITCH (Home Switch)		blue	MSWITCH

Encoder Cable and D37 Connector				
Pin ID	Pin Description Robot Side (J1)	Axis	Telephone Cable Color	Pin Description Controller Side (J2)
2	+5V	4	red	+5V
20	COMMON		yellow	COMMON 3
17	CHA4 (Encoder Pulse A)		green	CHA 3
18	CHB4 (Encoder Pulse B)		white	CHB 3
19	CHC4 (Encoder Index Pulse)		black	CHC 3
34	MSWITCH (Home Switch)		blue	MSWITCH
2	+5V	5	red	+5V
24	COMMON		yellow	COMMON 4
21	CHA5 (Encoder Pulse A)		green	CHA 4
22	CHB5 (Encoder Pulse B)		white	CHB 4
23	CHC5 (Encoder Index Pulse)		black	CHC 4
35	MSWITCH (Home Switch)		blue	MSWITCH
2	+5V	6	red	+5V
28	COMMON		yellow	COMMON 5
25	CHA6 (Encoder Pulse A)		green	CHA 5
26	CHB6 (Encoder Pulse B)		white	CHB 5
27	CHC6 (Encoder Index Pulse)		black	CHC 5
36	MSWITCH (Home Switch)		blue	MSWITCH

Maintenance

The maintenance and inspection procedures recommended below will ensure the best possible performance of the robot over an extended period.

Daily Operation

At the start of each working session, check the robot and controller, in the following order:

1. Before you power on the system, check the following items:
 - The installation meets all safety standards.
 - All cables are properly and securely connected.
Cable connector screws are fastened.
 - The gripper is properly connected.
The air supply (for a pneumatic gripper) is functioning properly.
 - Any peripheral devices or accessories which will be used, such as the teach pendant or a remote emergency button, are properly connected to the controller.
2. After you have powered on the system, check the following items:
 - No unusual noises are heard.
 - No unusual vibrations are observed in any of the robot axes.
 - There are no obstacles in the robot's working range.
3. Bring the robot to a position near home, and activate the Home procedure. Check the following items:
 - Robot movement is normal.
 - No unusual noise is heard when robot arm moves.
 - Robot reaches home position in every axis.

Periodic Inspection

The following inspections should be performed regularly:

- Check robot mounting bolts for looseness using a wrench. Retighten as needed.
- Check all visible bolts and screws for looseness using a wrench and screwdriver. Retighten as needed.
- Check cables. Replace if any damage is evident.

The following robot components may require replacing after prolonged use of the robotic arm causes them to wear or fail:

- DC Servo Motors
- Motor Brushes
- Timing Belts
- V-Rings
- Harmonic Drives
- Cross-Roller Bearings

Troubleshooting

Whenever you encounter a problem with your system, try to pinpoint its source by exchanging the suspected faulty component—for example, robot, controller, teach pendant, cable—with one from a functioning system.

In general, when trying to determine the source of a malfunction, first check the power source and external hardware, such as controller switches, LEDs and cable connections. Then check fuses; you may also open the controller to check components, according to the procedures and instructions detailed in the *Controller-B User's Manual*.

In addition, make sure the controller is properly configured for the robot and gripper, the software commands have been correctly issued, and system parameters are properly set.

All troubleshooting procedures described in the section can be performed by the user.

 **Do not attempt to open the robot arm.** *There are no user-serviceable parts inside.*

If you are unable to determine and/or correct the problem, contact your service representative. Only qualified technicians may remove and/or replace robot components.

1. *Controller's MOTORS switch does not turn on; the green LED does not light.*

- Make sure the Emergency button is released.
- Turn off the controller, disconnect it from the power source, and open the cover.

Check the 0.5A (SB) fuse (marked FAN/POWER/RELAYS)

2. *Controller functioning, but the robot cannot be activated.*

- Make sure an obstacle is not blocking the robot.
- Make sure the controller's MOTORS switch is on and the green LED is lit.
- Make sure the controller is in the control off (COFF) state. Then activate the control on (CON) state from PC or TP.
- Make sure all robot and encoder cables are properly connected.

- Check driver card fuses. Each driver card has a pair of LEDs and a pair of fuses (accessible from controller back panel). The upper LED and fuse correspond to the axis number at the top of the card; the lower LED and fuse correspond to the axis number at the bottom of the card.

Both LEDs on each card in use should be lit, indicating that power is being supplied to the axis driver. If one of the LEDs is not lit, remove the fuse for the corresponding axis and examine it. (To remove the fuse, press it in and rotate counter-clockwise.)

3. *Robot does not find Home position in one or all of the axes.*

- Make sure the homing command was properly issued.
- Make sure all robot and encoder cables are properly connected.
- If the robot has just undergone maintenance or repair, use the command ZSET. Then issue the home command.
- Make sure system homing parameters have not been erased.
Make sure system homing parameters are properly set.
Refer to the *ACL Reference Guide*.

- Check whether the optical home switch for this axis is functioning.

Manually move the faulty axis (from teach pendant or keyboard) and check the value of system variable HS[n] (where n is the index of the axis). The value of HS will change to either 1 or 0 (defined by parameter 560+axis) when the home switch is detected.

To help you perform this test, prepare and continuously run a simple ACL program, as follows:

```
LABEL 1
PRINTLN HS[n]
DELAY 20
GOTO 1
```

If the value of HS does not change, possible causes:

- Faulty arm circuitry.
- Faulty optical switch; optical switch not properly mounted.
- Faulty driver circuitry
- Problem in controller power supply unit +5V1.

4. *One of the axes does not function.*

- Check the driver card LED for this axis at the back of the controller. If the LED is not lit, check the corresponding fuse.
- Check the motor drive circuitry.
- Check the encoder:
Enter the command SHOW ENCO to display the encoder readings.
Enter the command COFF (to disable servo control) and then *physically* move the axis in question in both directions.
The encoder reading should rise for rotation in one direction and fall for rotation in the opposite direction. If this does not occur, there is a problem in the encoder or its circuitry.
If the encoder readings do not change, check whether the encoder connector is properly connected to the rear controller panel.
The problem may be caused by faulty encoder connectors on the robot's internal PCB's.

5. *Motors suddenly stop. No message on screen. No response to keyboard entries.*

- Check the power source.
- Make sure the MOTORS power switch is on; make sure the Emergency button is not depressed.
- Turn off the controller and open up the cover. Turn on the controller. Check the yellow “watchdog” LED on the main board. If it is lit, it indicates that that one of the following fuses on the power supply unit has blown out: +12VA, -12VA, +12VDR, -12VDR.
Turn off the controller and disconnect it from the power source. Check each of these four fuses. Replace the blown fuse.

6. *Errors in the repeatability of the robot.*

- Try to identify the faulty axis. If many or all axes are faulty, look for an electrical noise source in your environment.
- Check the controller's ground and the robot's ground connection to the safety ground terminal at the back of the controller.
- Check the encoder.

Bring the robot to a starting position. Using a pencil, draw a fine, continuous line on the robot which crosses from the cover of one link to the cover of the adjacent link at the joint in question.

Enter the command `SHOW ENCO` to display the encoder readings. Enter the command `COFF` (to disable servo control) and then *physically* move the axis to another position. Then return to the starting position marked by the line you drew. Check the encoder reading for the axis again. It should be within 5 counts of the previous reading; if not, the encoder needs to be replaced.

7. *Unusual noise.*

- Loose screws.
- Poor lubrication.
- Ratcheting.
- Worn motor brushes.
- Worn timing belt.
- Damaged harmonic drive.

8. *Unusual smell.*

- A motor has burnt out and needs to be replaced.

9. *Axis/axes vibrating, too weak to carry load, motion not smooth, or jerks during or at end of motion.*

- System parameters are not properly adjusted.
Refer to the *ACL Reference Guide*.
- Problem in axis driver card(s) in the controller.
Refer to the *Controller-B User's Manual*.

10. *Pneumatic gripper does not respond.*

- Check that all air hoses are connected properly.
- Make sure the gripper is connected to the proper controller output.
- Check the relay output to which the gripper is connected.

Check whether the relays have been switched (LED is lit):

- In output OFF, NC is shorted to COM, NO is disconnected from COM.
- In output ON, NO is shorted to COM, NC is disconnected from COM.

If outputs have not been switched, check the flat cable in the controller connecting the main board (J17) and the I/O card.

Messages

Following is a alphabetical listing of system messages which indicate a problem or error in the operation of the robot arm. Refer to the *ACL Reference Guide* for additional error messages.

Axis disabled.

(1) A movement command could not be executed because servo control of the arm has been disabled (COFF).

(2) A previous movement of the arm resulted in an Impact or Trajectory error, thereby activating COFF and disabling the arm.

- Check the movements of the robot, and correct the command(s).

CONTROL DISABLED.

Motors have been disconnected from servo control. Possible causes:

(1) COFF (control off) command was issued.

(2) CON (control on) has not been issued; the motors have not been activated.

(3) A previous error (such as Impact Protection, Thermic Overload or Trajectory Error) activated COFF, thereby disabling the arm.

***** HOME FAILURE AXIS *n*.**

The homing procedure failed for the specified axis. Possible causes:

(1) The home microswitch was not found.

(2) The motor power supply is switched off.

(3) Hardware fault on this axis.

Home on group/axis not done.

You attempted to move the arm to a recorded positions, or to record a position, before homing was performed on the group or axis.

***** IMPACT PROTECTION axis n**

The controller has detected a position error which is too large. The system aborted all movements of that axis group, and disabled all axes of that group. The user routine CRASH, if it exists, has been executed. Possible causes:

- (1) An obstacle prevented the movement of the arm.
- (2) An axis driver fuse has blown.
- (3) The motor power switch is turned off.
- (4) An encoder fault.
- (5) A mechanical fault.
- (6) The axis is not connected.

- Determine and correct the cause of the position error. Then reenable servo control of the motors (CON), and restart the program.

INDEX pulse not found axis n

The index pulse of the encoder was not found during the homing of the specified axis. Possible causes:

- (1) The distance between the index pulse and the home switch transition position has changed, due to a mechanical fault on the axis or a maintenance procedure (such as replacement of the motor, motor belt, encoder, or gear).

- Enter the command ZSET. Then retry homing.

- (2) Index pulse faulty.

- Check the encoder and wiring.

***** LOWER LIMIT AXIS n.**

During keyboard or TP manual movement of the specified axis, its encoder attained its minimum allowed value.

- Move the axis in the opposite direction.

Motor power switch is OFF.

Be sure the controller's MOTORS switch is on. Activate CON. Then repeat the motor or movement command.

No hard homing axis n.

The specified axis has not been configured for hard homing.

- Use the HOME command (instead of HHOME). OR
- Check the type of homing suitable for that axis. If necessary, change the system parameters to allow hard homing of the axis.

No homing.

The homing parameters for the axis (PAR 460+axis and PAR 600+axis) are set to 0; as a result, the homing procedure will not be performed on the axis.

***** OUT OF RANGE axis n**

An attempt was made to record a position (HERE, HEREC, etc.) while the robot arm was out of its working envelope.

- Manually move the arm to a location within its working envelope. Then repeat the command.

***** THERMIC OVERLOAD axis n**

Through a software simulation of motor temperature, the system has detected a dangerous condition for that motor. The system aborted all movements of that axis group, and disabled all axes of that group. The user routine CRASH, if it exists, has been executed. Possible causes:

(1) The arm attempted to reach a position, which could not be reached due to an obstacle (for example, a position defined as being above a table, but actually slightly below the table's surface). The impact protection is not activated because the obstacle is close to the target position. However, integral feedback will increase the motor current and the motor will overheat, subsequently causing the Thermic Protection to be activated.

(2) An axis driver is faulty or its fuse has blown.

(3) The robot arm is near to the target position, but does not succeed in reaching it, due to a driver fault. The software will then detect an abnormal situation.

(4) The Thermic Protection parameters are improperly set, or have been corrupted by improper loading of parameters.

- Check the positions, the axis driver card and parameters. Reenable servo control of the motors (CON).

***** TOO LARGE SPEED axis n.**

Possible causes:

(1) The controller has detected a movement which is too fast; that is, the required displacement of the encoder, as calculated from the speed limit parameter, PAR 180+axis, is too great.

(2) Since the trajectory is not calculated prior to a linear or circular movement, the linear or circular movement may cause one of the joints to move too fast.

- Lower the value of speed for that movement.

***** TRAJECTORY ERROR !**

During movement, the robot arm reached its envelope limits, and the system aborted the movement. This may occur when executing the following types of movements: linear (MOVEL), circular (MOVEC) , MOVES, and SPLINE. Since the trajectory is not computed prior to motion, the movement may exceed the limits of the working envelope.

- Modify the coordinate values of the positions which define the trajectory.

***** UPPER LIMIT AXIS *n***

During keyboard or TP manual movement of the specified axis, its encoder attained its maximum allowed value.

- Move the axis in the opposite direction.